

CU-ROBOTARM (AddOn for mobile robots)

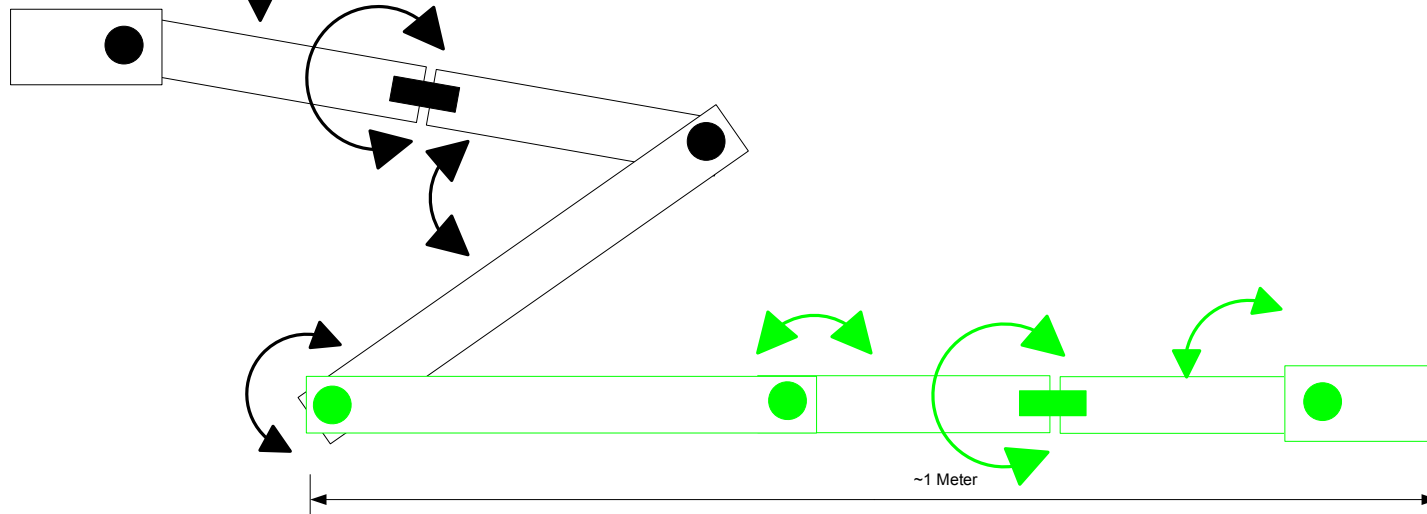
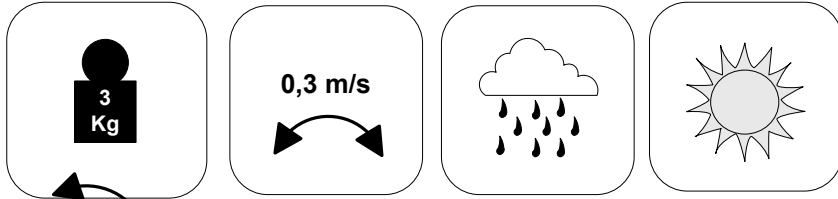

Sollte in diesem Plan oder in dessen begleitenden Dokumenten noch der ein oder andere Fehler drin stecken, so bitte ich um Nachsicht und Hinweise per Mail an christian@ulrichc.de.

Änderungen und Ergänzungen dieses Dokuments sind im Downloadbereich bei <http://www.UlrichC.de/> an der Versionsnummer erkennbar!

Product:CU-ROBOTARM
 File: BASE
 Version: 1
 Date: 20.01.2009
 Last Modify:-

UlrichC
 © 2009 Christian Ulrich
 All rights reserved

UlrichC.DE
 INTERNET: <http://www.ulrichc.de/>
 E-MAIL : info@ulrichc.de

8 7 6 5 4 3 2 1

CU-ROBOTARM (Ausleger)

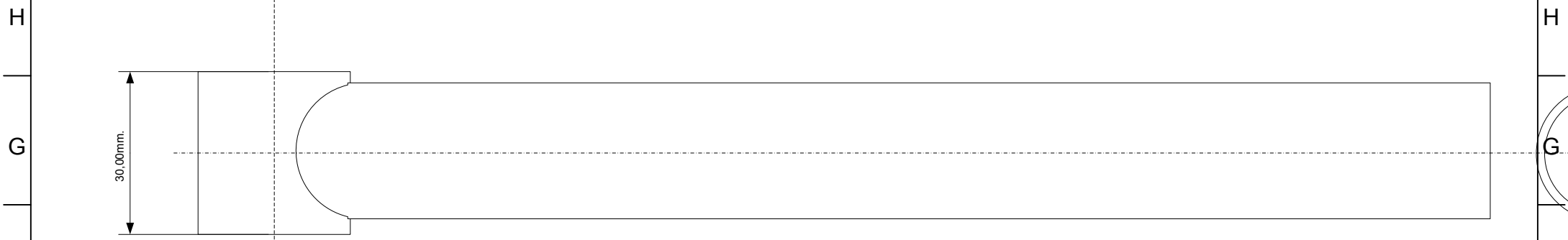

Ausleger Lagerbuchsen AL1

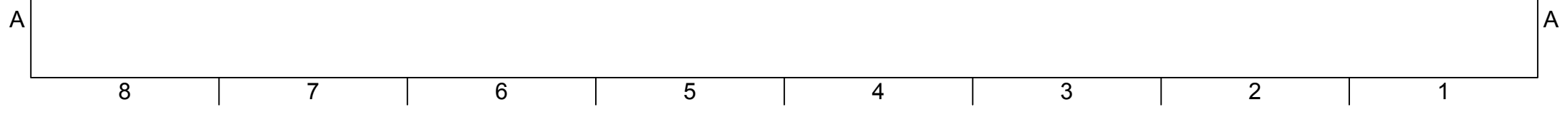
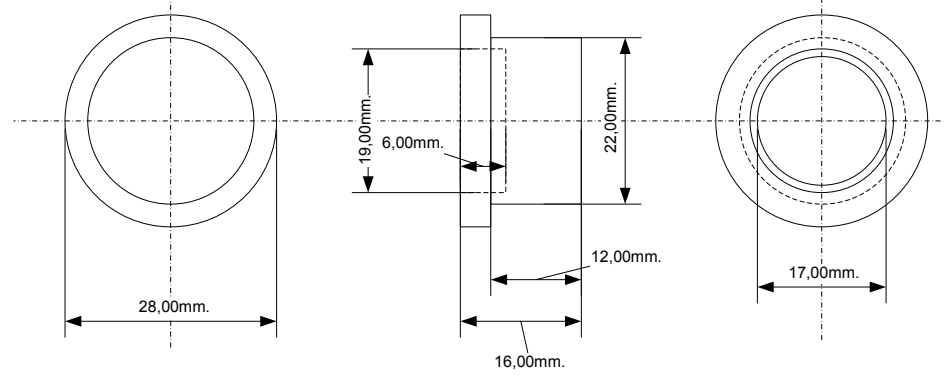

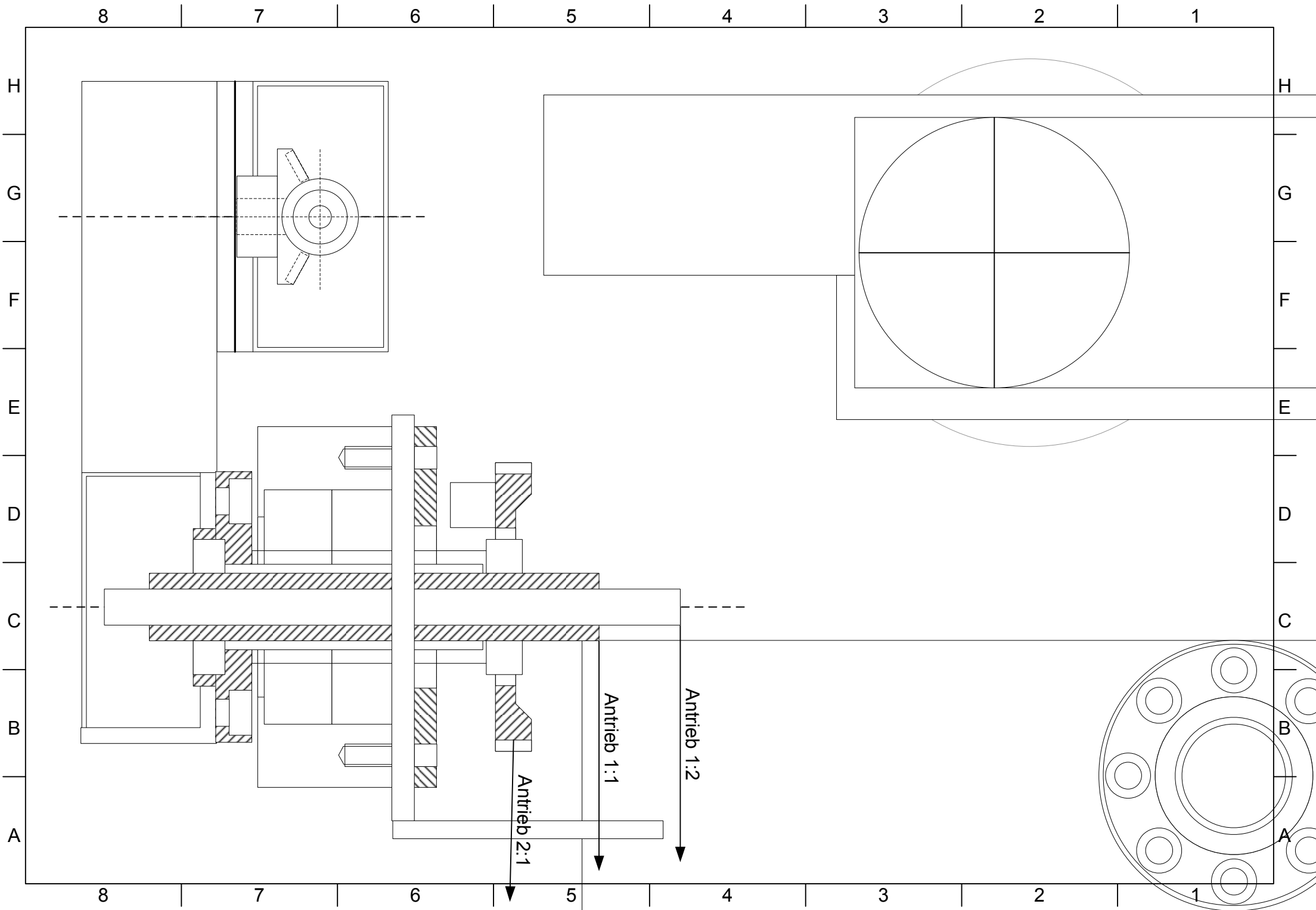

8 7 6 5 4 3 2 1

H Radiallager

G

F

E

D

C

B

A

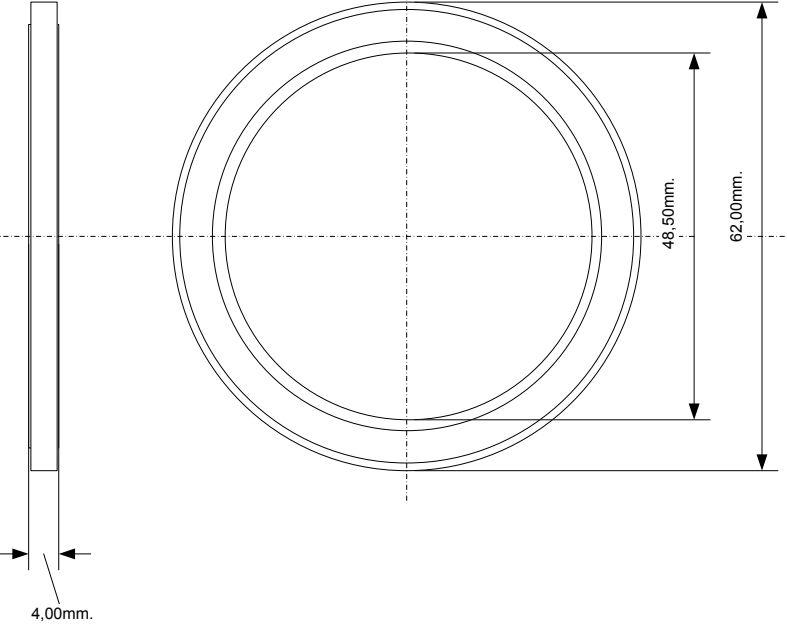

Zahnrad

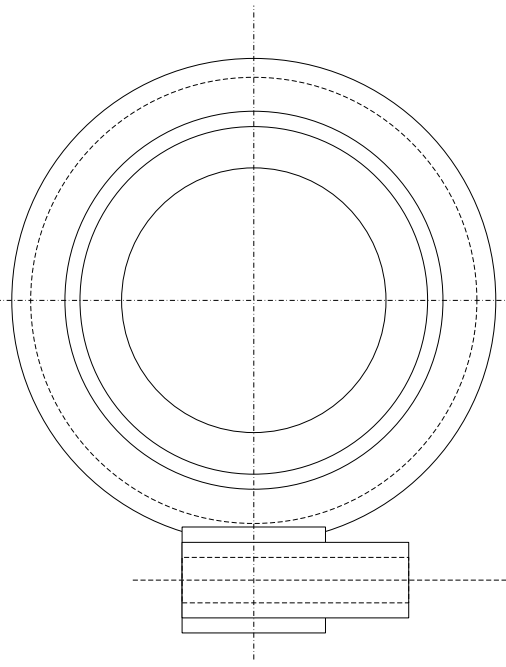

Kegeltrieb

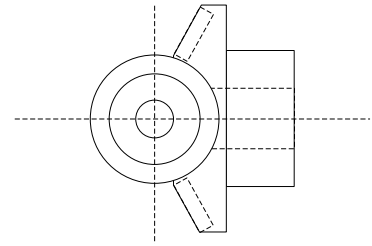
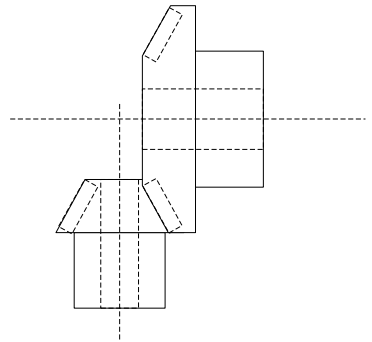

8 7 6 5 4 3 2 1

H

G

F

E

D

C

B

A

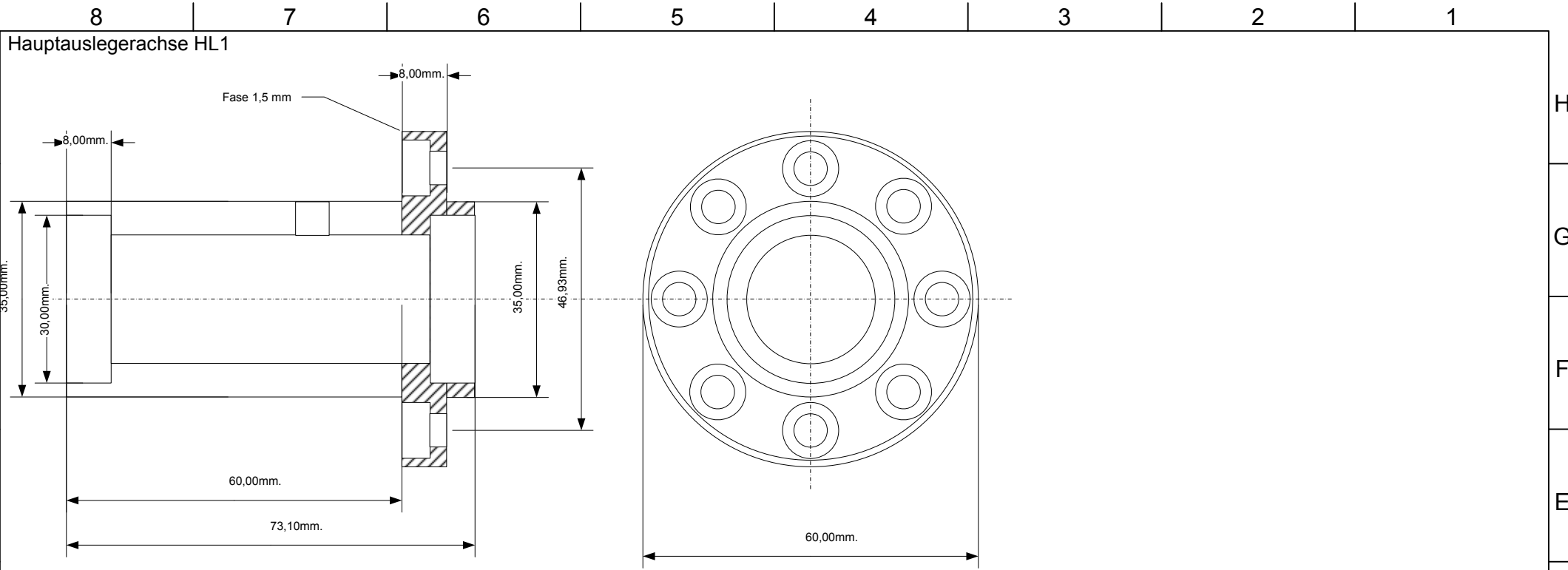

Hauptauslegerlager HL2

Hauptauslegerlagerscheibe HL3

