

CU-CNC (CNC-Fräsmaschine)

CU-CNC

Z-Achse

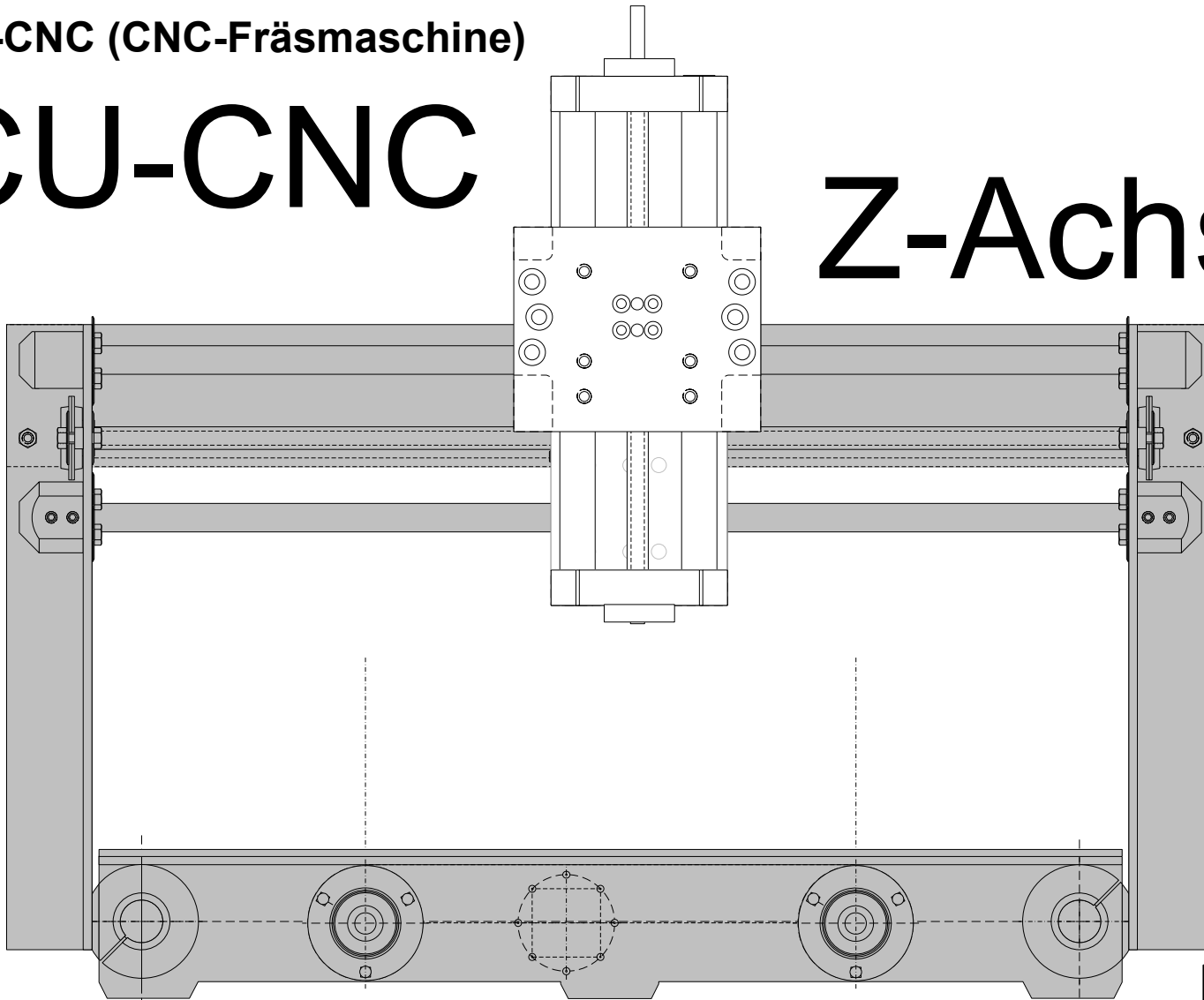

Sollte in diesem Plan oder in dessen begleitenden Dokumenten noch der ein oder andere Fehler drin stecken, so bitte ich um Nachsicht und Hinweise per Mail an christian@ulrichc.de.

Änderungen und Ergänzungen dieses Dokuments sind im Downloadbereich bei <http://www.ulrichc.de/> an der Versionsnummer erkennbar!

Product:CU-CNC
File: Z-Achse
Version: 1
Date: 30.11.2009
Last Modify: -

UlrichC
© 2009 Christian Ulrich
All rights reserved

UlrichC.DE
INTERNET: <http://www.ulrichc.de/>
E-MAIL : info@ulrichc.de

Z-Führungswagen

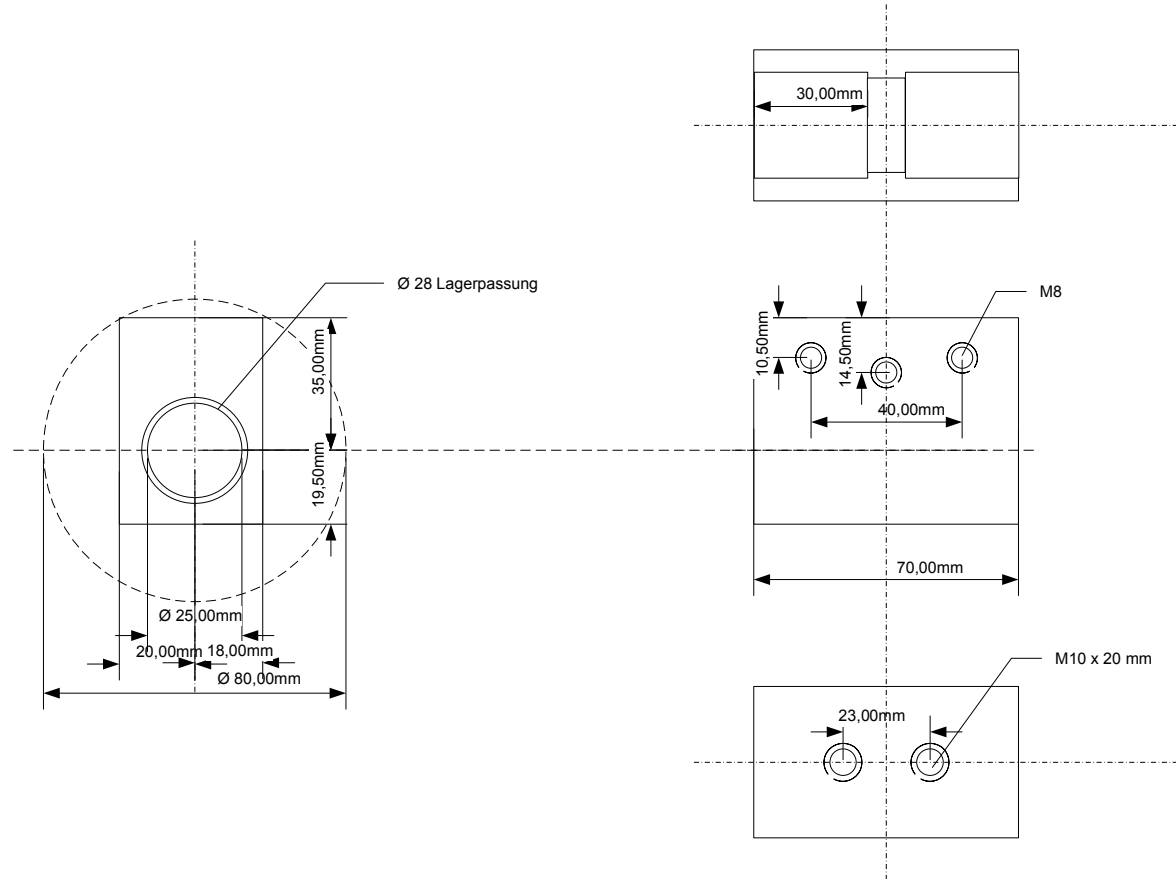

Product: CU-CNC
 File: Z-Achse
 Version: 1
 Date: 30.11.2009
 Last Modify: -

UlrichC
 © 2009 Christian Ulrich
 All rights reserved

UlrichC.DE
 INTERNET: <http://www.ulrichc.de/>
 E-MAIL : info@ulrichc.de

Z-Führungswagen Montage

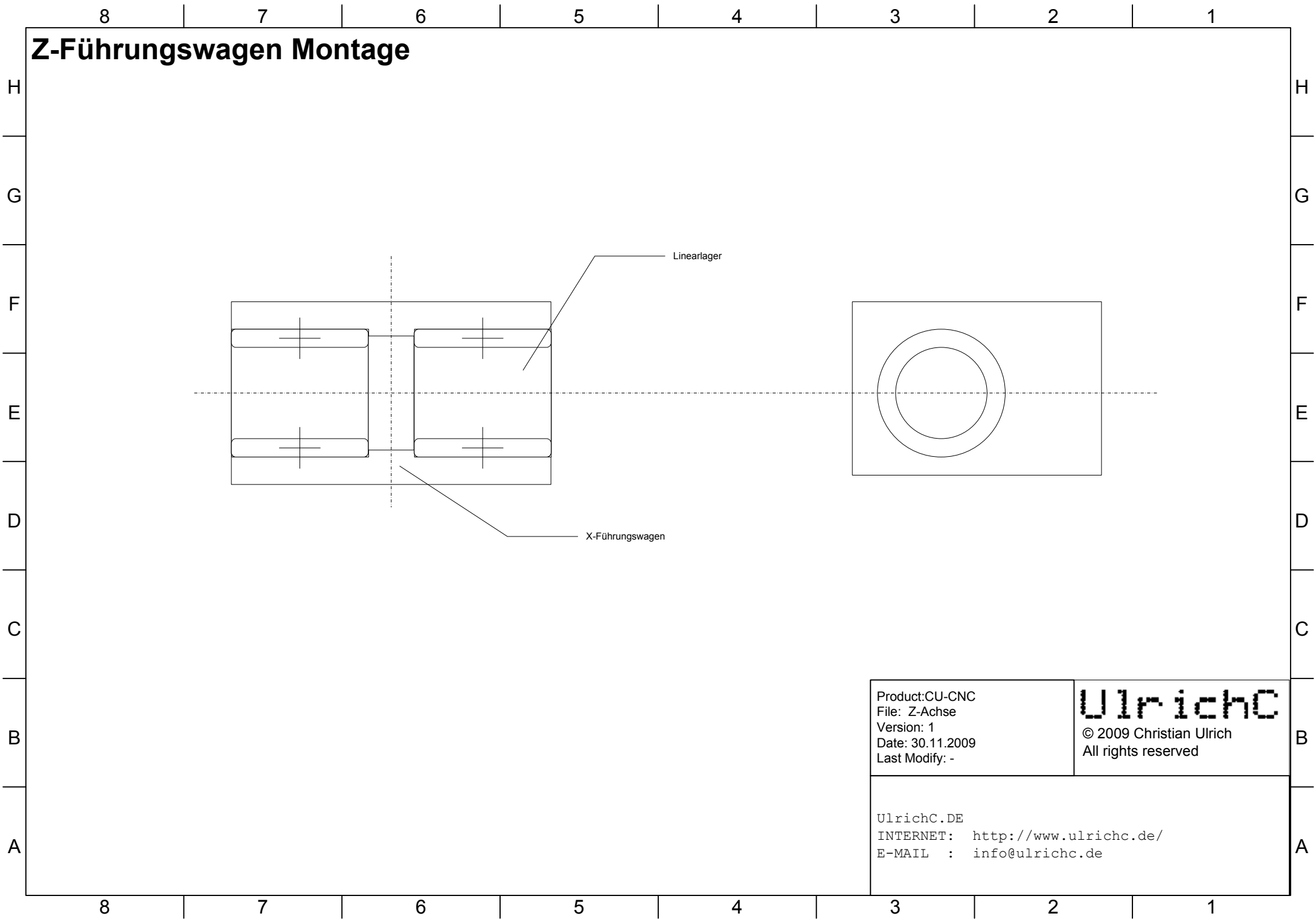

Product:CU-CNC
File: Z-Achse
Version: 1
Date: 30.11.2009
Last Modify: -

UlrichC
© 2009 Christian Ulrich
All rights reserved

UlrichC.DE
INTERNET: <http://www.ulrichc.de/>
E-MAIL : info@ulrichc.de

Z-Spindelmutter

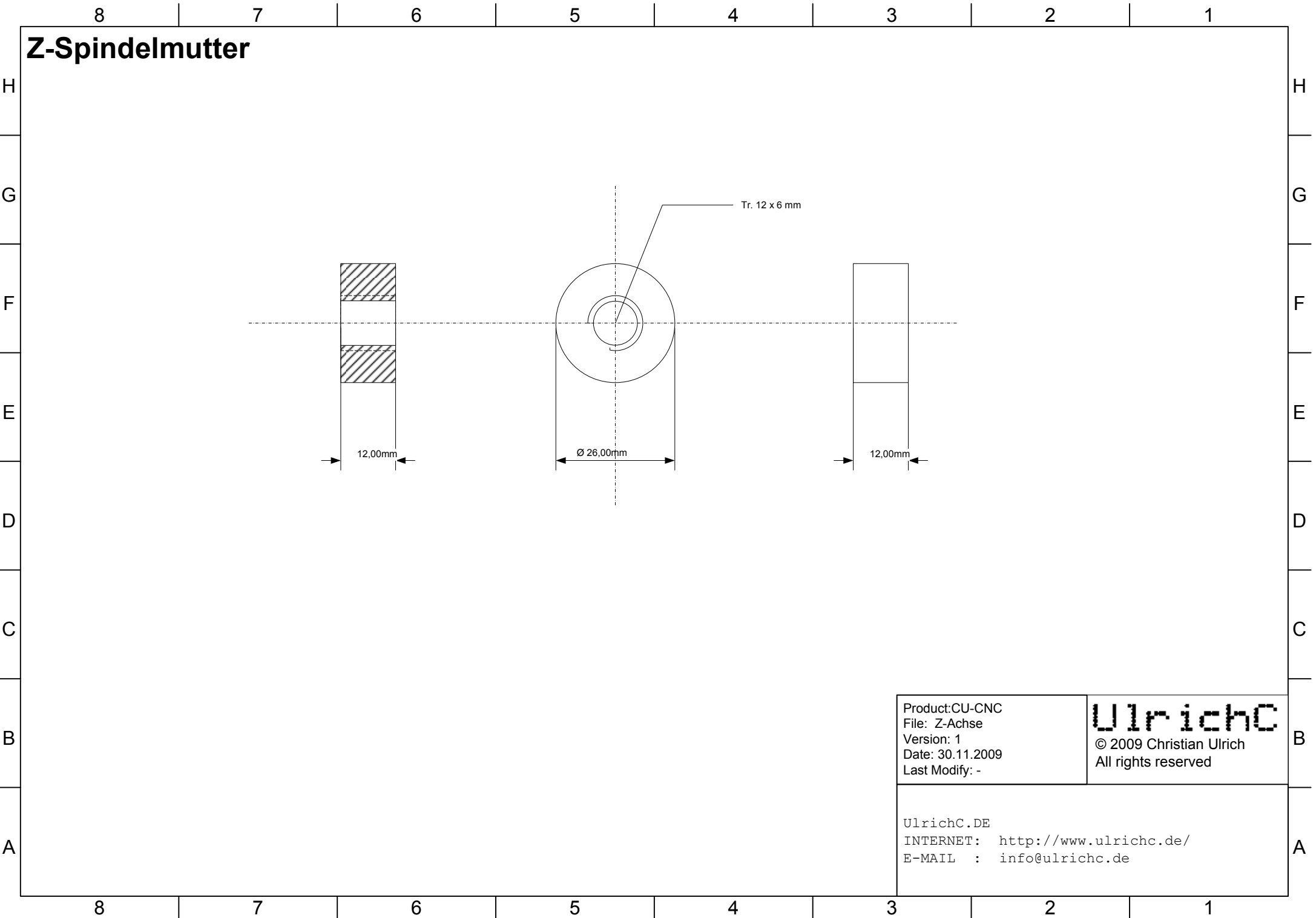

Product:CU-CNC
File: Z-Achse
Version: 1
Date: 30.11.2009
Last Modify: -

UlrichC
© 2009 Christian Ulrich
All rights reserved

UlrichC.DE
INTERNET: <http://www.ulrichc.de/>
E-MAIL : info@ulrichc.de

Z-Spindelmutter- Gehäuse

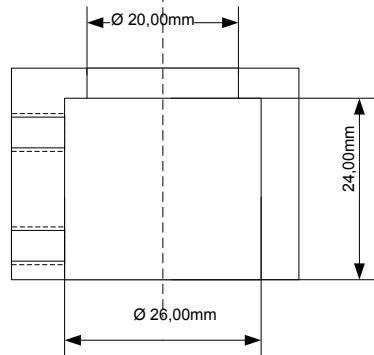
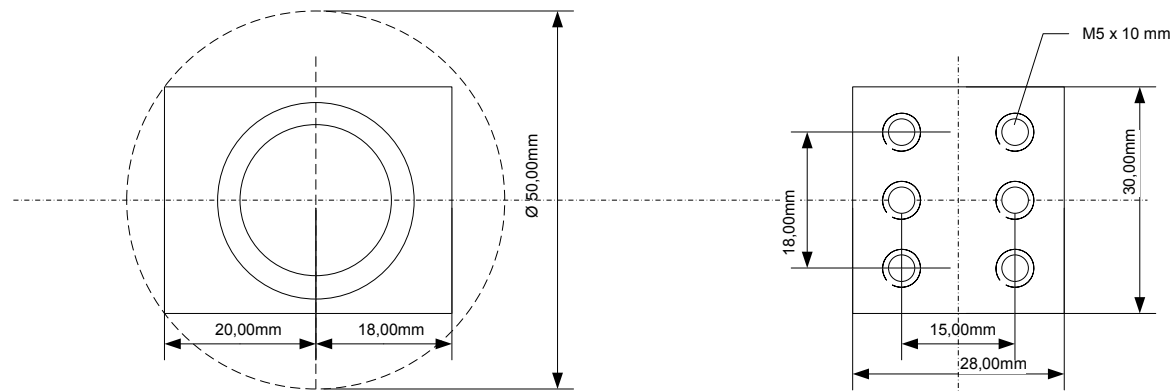

Product:CU-CNC
File: Z-Achse
Version: 1
Date: 30.11.2009
Last Modify: -

UlrichC
© 2009 Christian Ulrich
All rights reserved

UlrichC.DE
INTERNET: <http://www.ulrichc.de/>
E-MAIL : info@ulrichc.de

Z-Spindelmutter- Gehäuse (Montage)

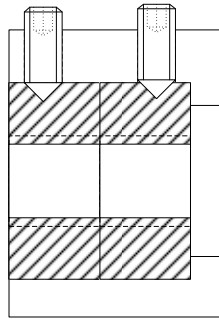

Product:CU-CNC
File: Z-Achse
Version: 1
Date: 30.11.2009
Last Modify: -

UlrichC
© 2009 Christian Ulrich
All rights reserved

UlrichC.DE
INTERNET: <http://www.ulrichc.de/>
E-MAIL : info@ulrichc.de

Z-Spindellager-Gehäuse

Lagergehäuse

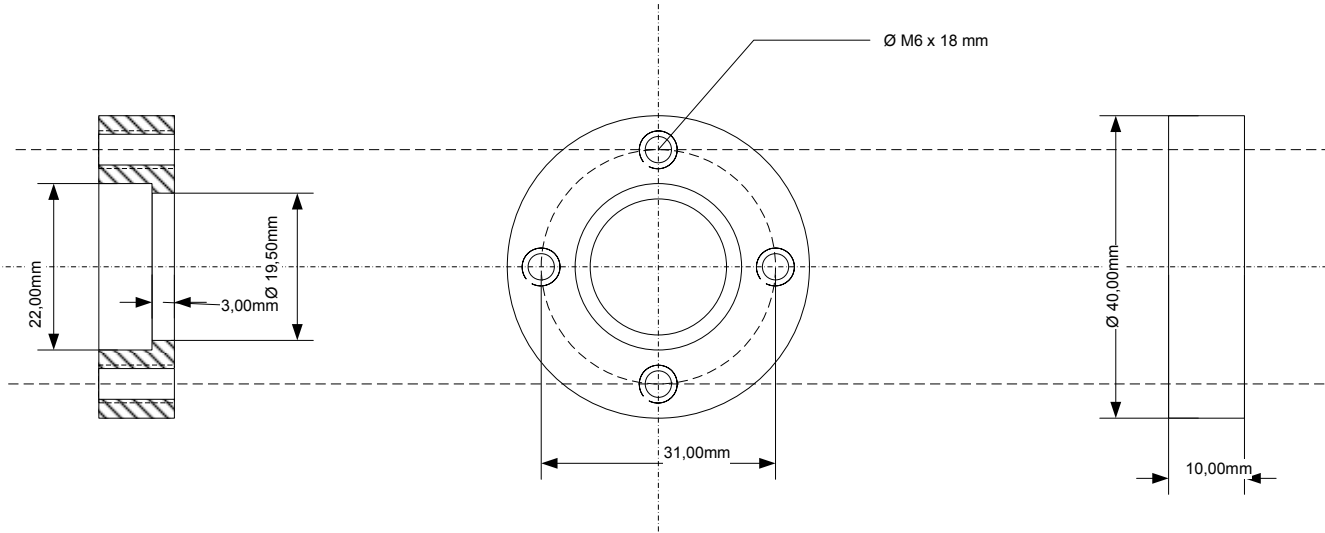

Product:CU-CNC
File: Z-Achse
Version: 1
Date: 30.11.2009
Last Modify: -

UlrichC
© 2009 Christian Ulrich
All rights reserved

UlrichC.DE
INTERNET: <http://www.ulrichc.de/>
E-MAIL : info@ulrichc.de

Z-Spindellager (Montage)

Lager

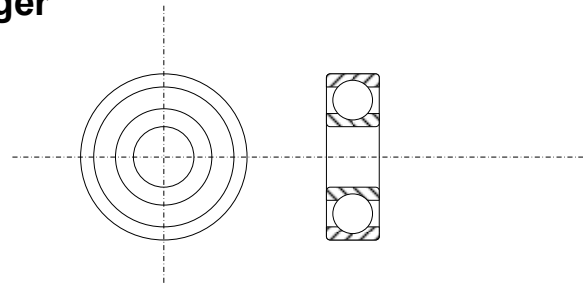

(Montage)

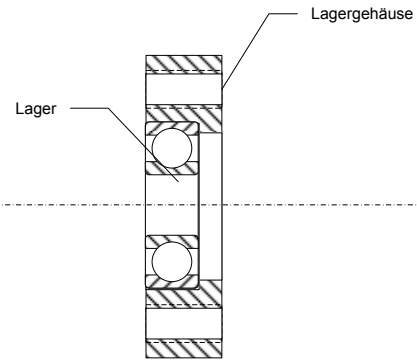

Product:CU-CNC
File: Z-Achse
Version: 1
Date: 30.11.2009
Last Modify: -

UlrichC
© 2009 Christian Ulrich
All rights reserved

UlrichC.DE
INTERNET: <http://www.ulrichc.de/>
E-MAIL : info@ulrichc.de

Z-Spindel

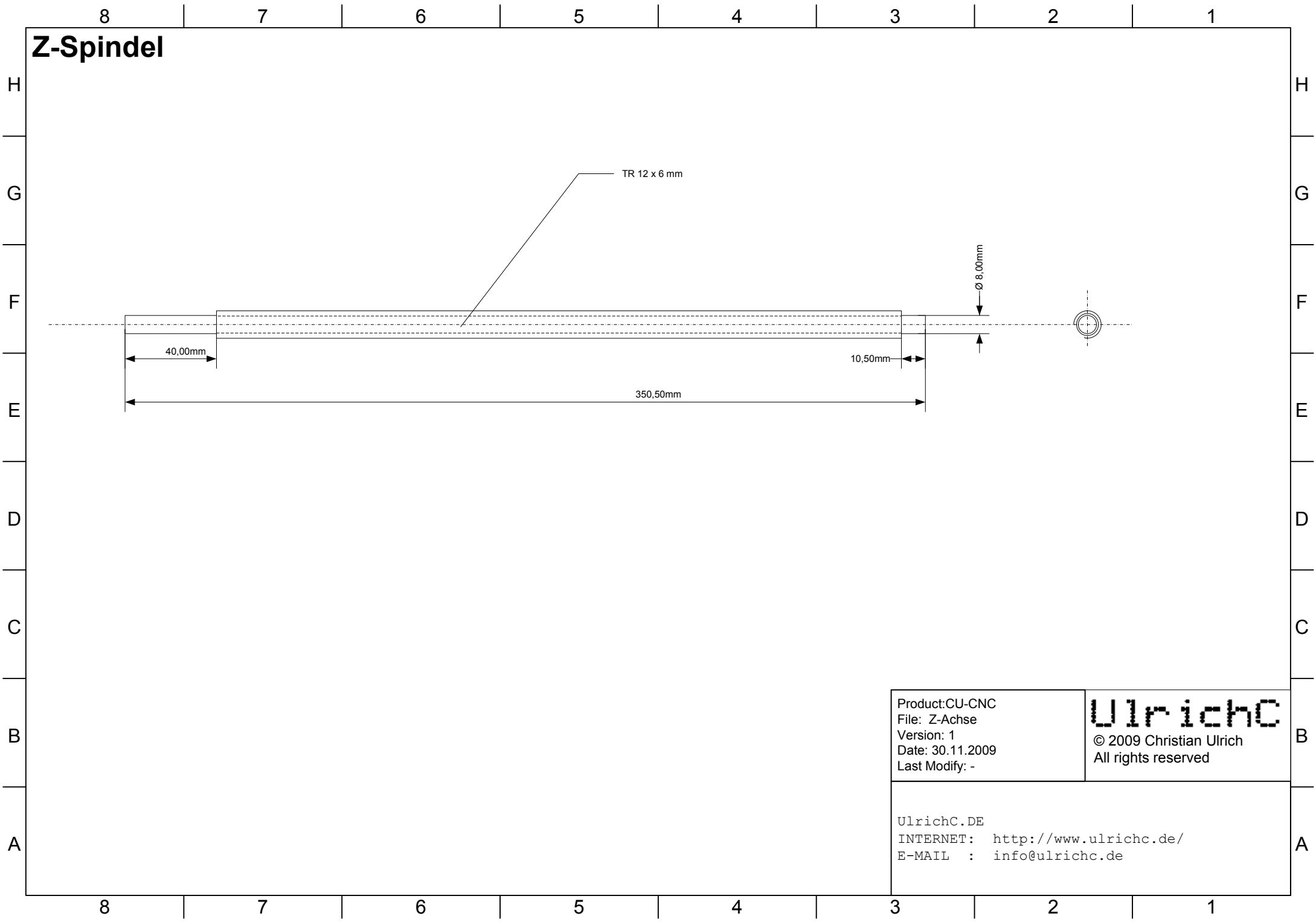

Product:CU-CNC
File: Z-Achse
Version: 1
Date: 30.11.2009
Last Modify: -

UlrichC
© 2009 Christian Ulrich
All rights reserved

UlrichC.DE
INTERNET: <http://www.ulrichc.de/>
E-MAIL : info@ulrichc.de

Z-Grundplatte

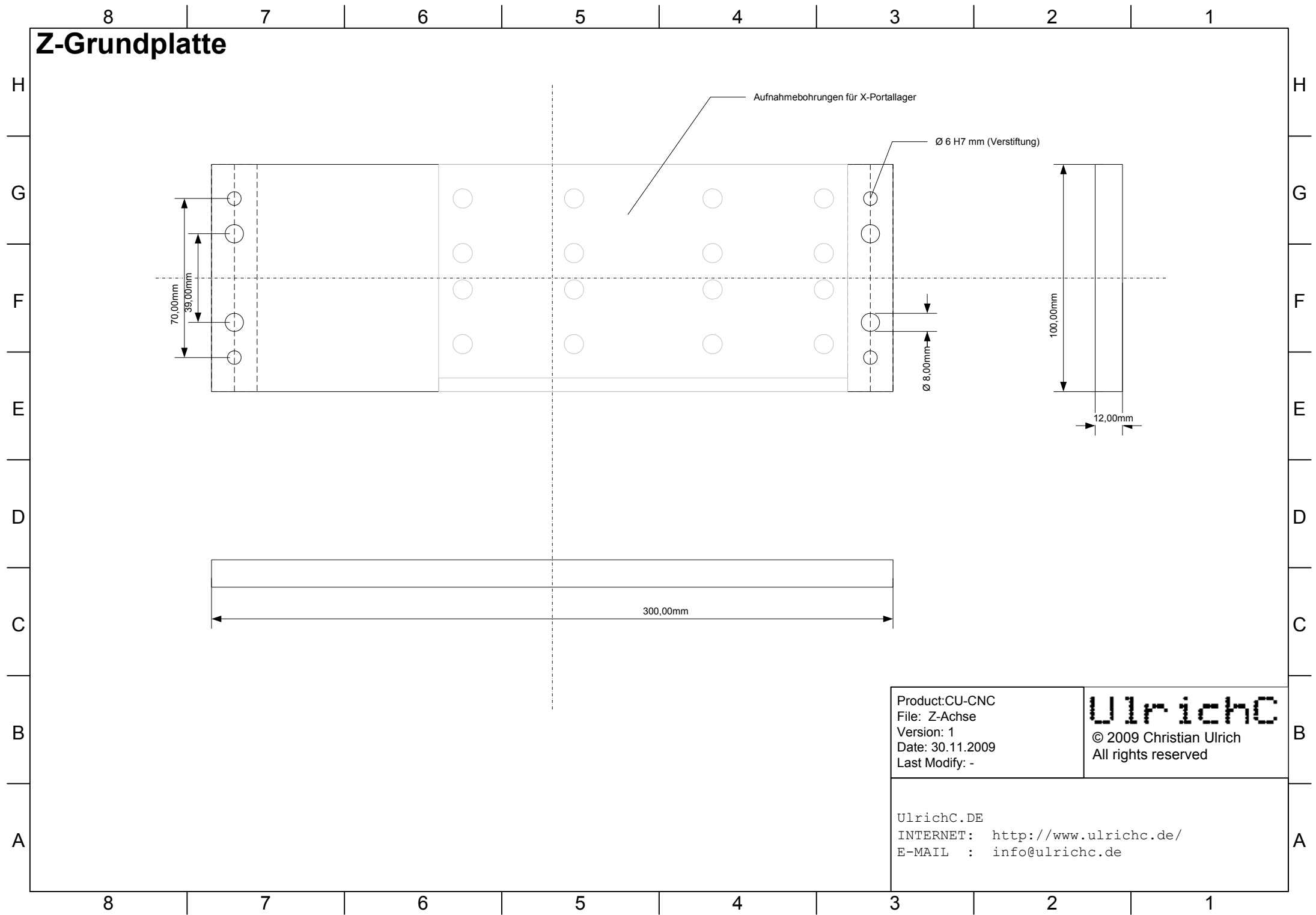

Product:CU-CNC
File: Z-Achse
Version: 1
Date: 30.11.2009
Last Modify: -

UlrichC
© 2009 Christian Ulrich
All rights reserved

UlrichC.DE
INTERNET: <http://www.ulrichc.de/>
E-MAIL : info@ulrichc.de

Z-Führungsblock

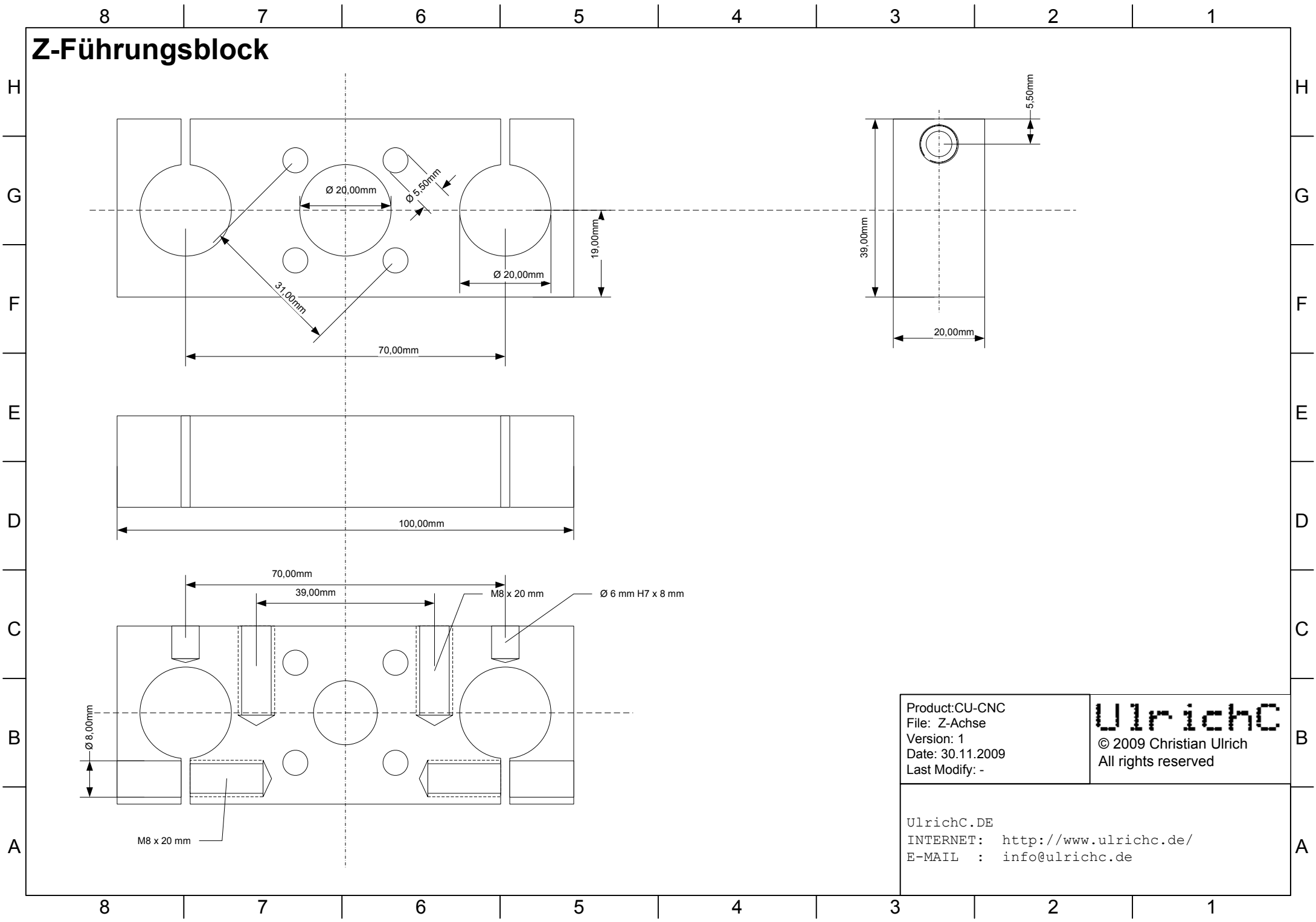

Product:CU-CNC
 File: Z-Achse
 Version: 1
 Date: 30.11.2009
 Last Modify: -

UlrichC
 © 2009 Christian Ulrich
 All rights reserved

UlrichC.DE
 INTERNET: <http://www.ulrichc.de/>
 E-MAIL : info@ulrichc.de

Z-Führungswelle

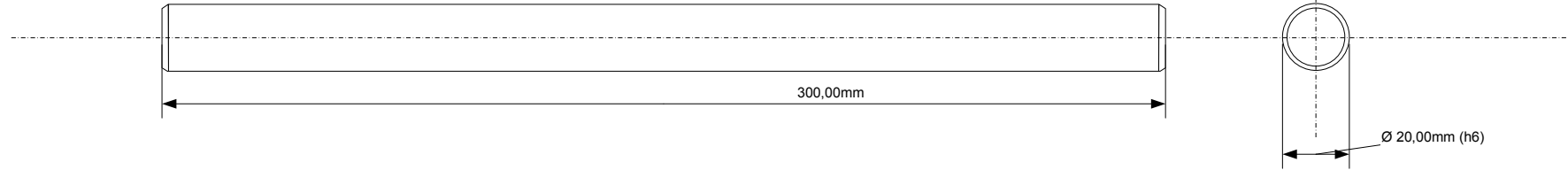

Product:CU-CNC
File: Z-Achse
Version: 1
Date: 30.11.2009
Last Modify: -

UlrichC
© 2009 Christian Ulrich
All rights reserved

UlrichC.DE
INTERNET: <http://www.ulrichc.de/>
E-MAIL : info@ulrichc.de

Z-Führung Montage

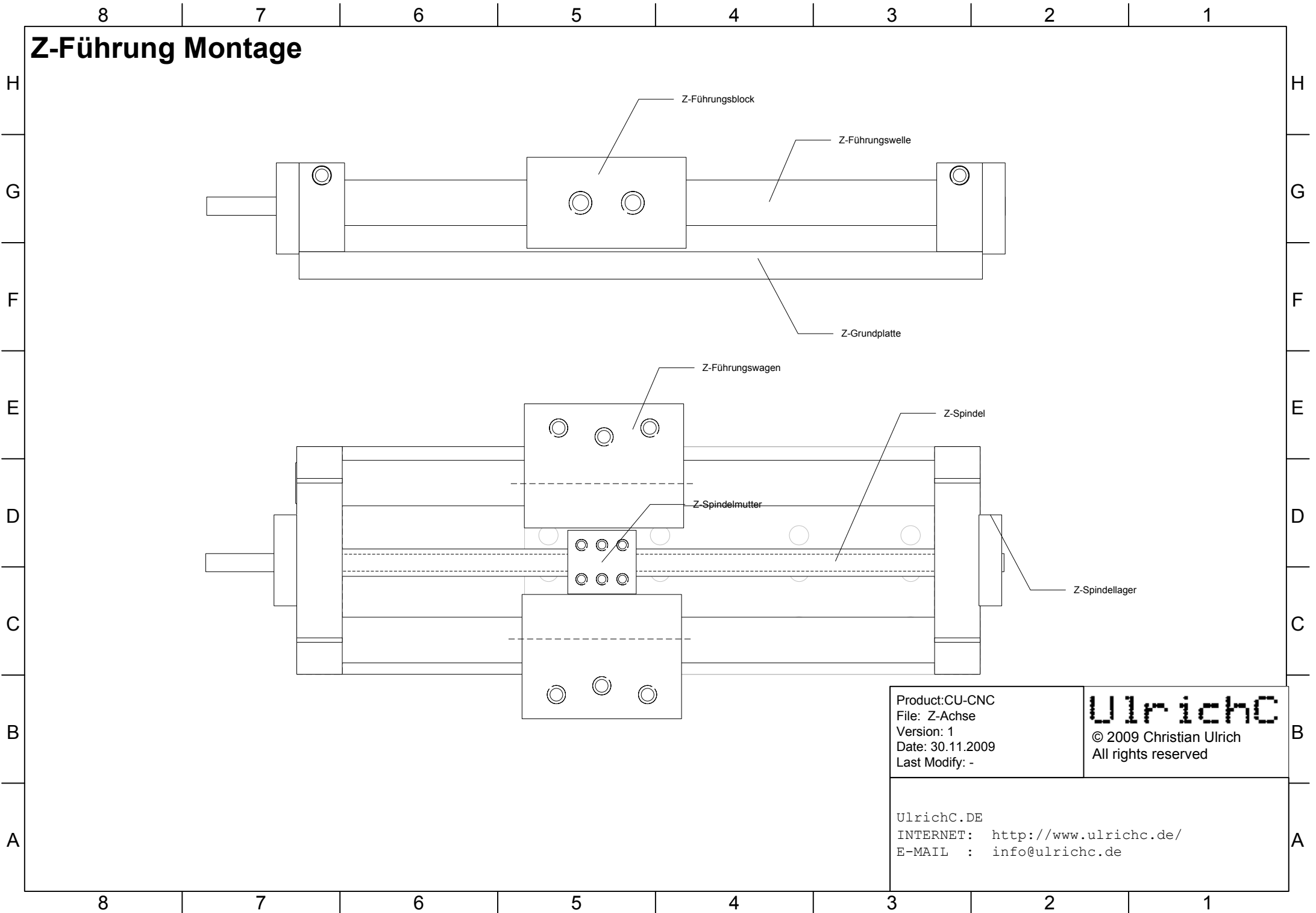

Product:CU-CNC
File: Z-Achse
Version: 1
Date: 30.11.2009
Last Modify: -

UlrichC
© 2009 Christian Ulrich
All rights reserved

UlrichC.DE
INTERNET: <http://www.ulrichc.de/>
E-MAIL : info@ulrichc.de

Z-Motor-Flanschplatte

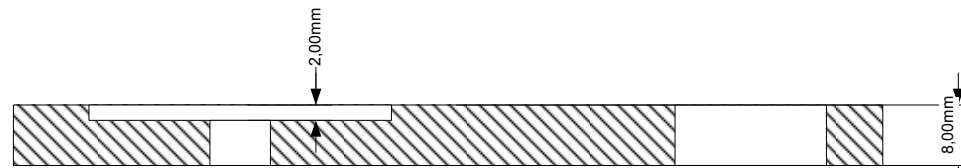
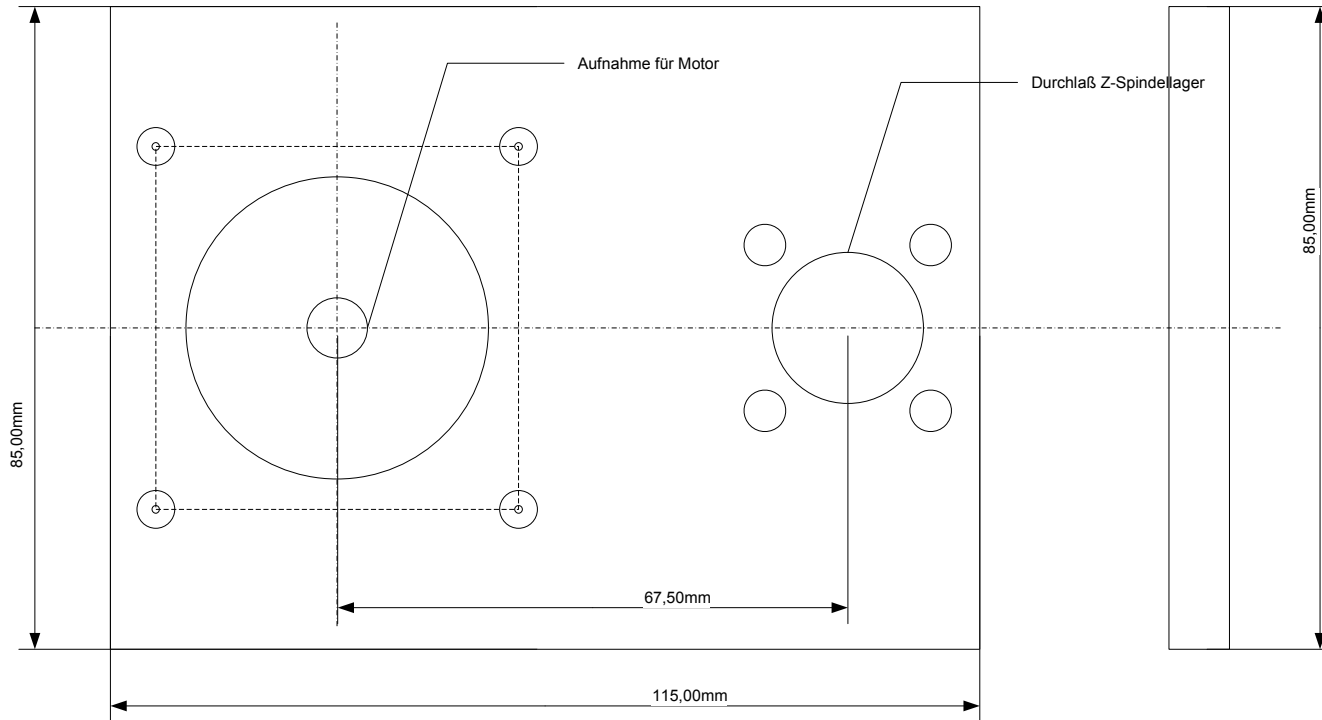

Product:CU-CNC
File: Z-Achse
Version: 1
Date: 30.11.2009
Last Modify: -

UlrichC
© 2009 Christian Ulrich
All rights reserved

UlrichC.DE
INTERNET: <http://www.ulrichc.de/>
E-MAIL : info@ulrichc.de

Z-Lager

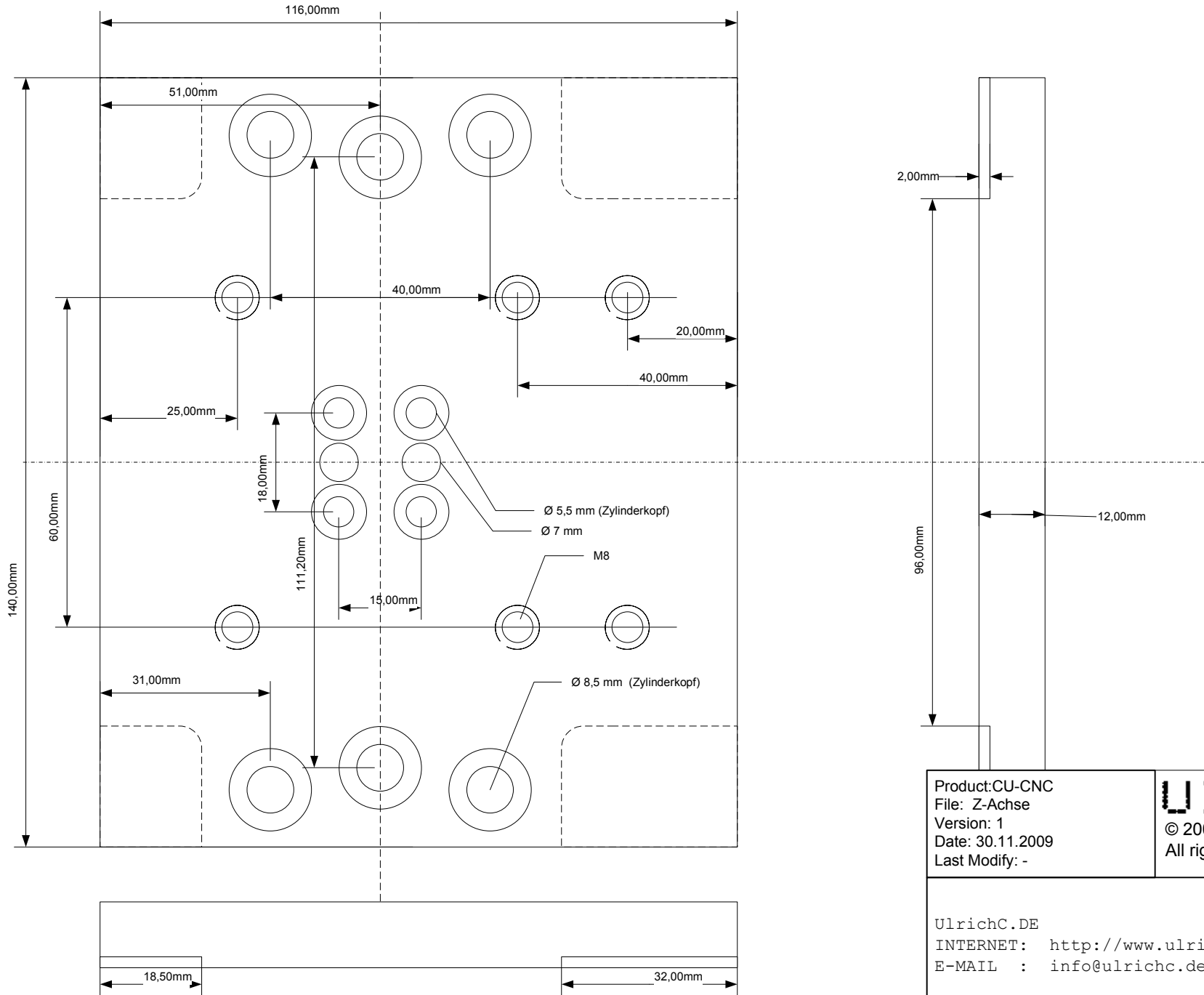

Product: CU-CNC
File: Z-Achse
Version: 1
Date: 30.11.2009
Last Modify: -

UlrichC
© 2009 Christian Ulrich
All rights reserved

UlrichC.DE
INTERNET: <http://www.ulrichc.de/>
E-MAIL : info@ulrichc.de